

QUAIL RUN TOWNHOMES

* COMMON AREA NOTE:
ALL OF THE AREA CONTAINED WITHIN THE BOUNDARY OF THIS PLAT SHALL BE COMMON AREA WITH THE EXCEPTION OF THE AREA WITHIN EACH NUMBERED LOT.

NORTH

QUIET WOOD SUBDIVISION
PLAT BOOK 5, PG. 149

FIRST ADDITION TO
QUIET WOOD SUBDIVISION
PLAT BOOK 6, PG. 44

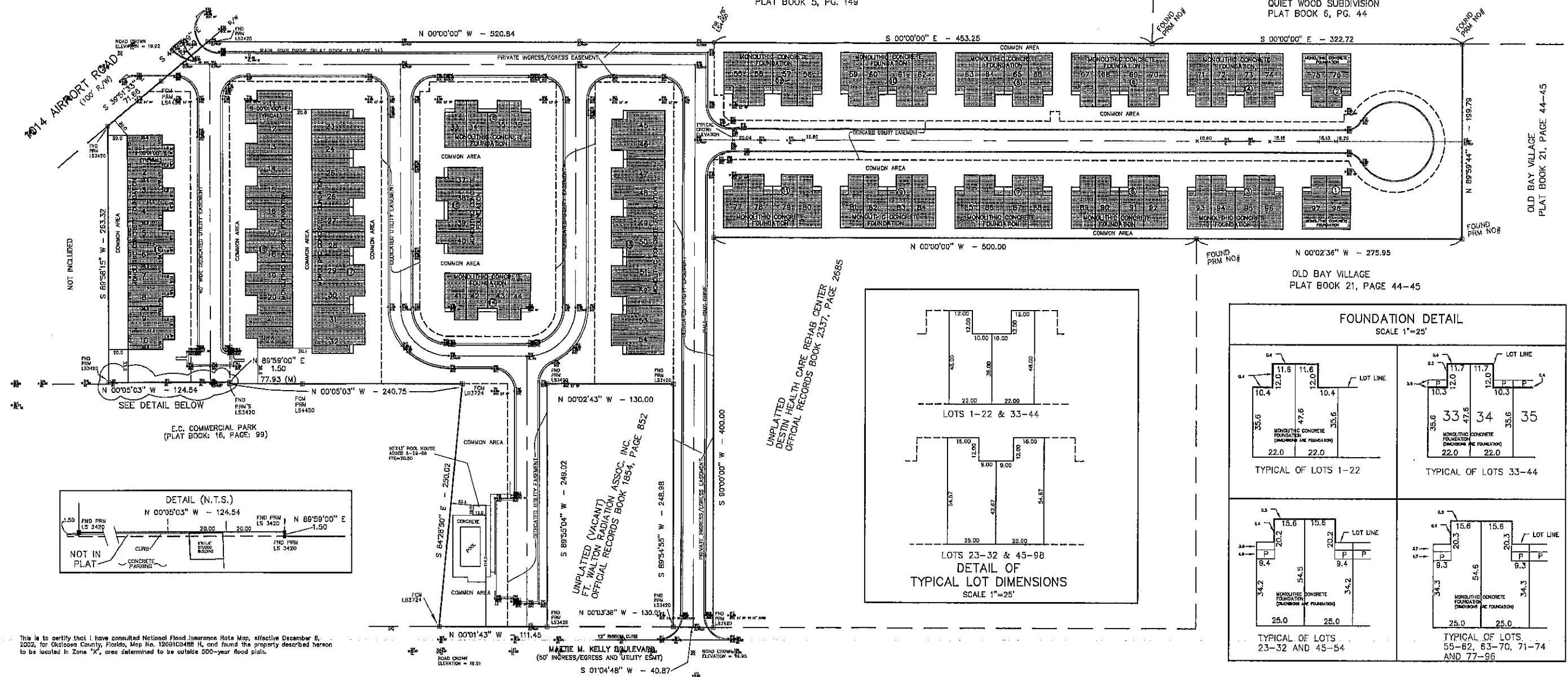

E.C. COMMERCIAL PARK
(PLAT BOOK: 16, PAGE: 99)

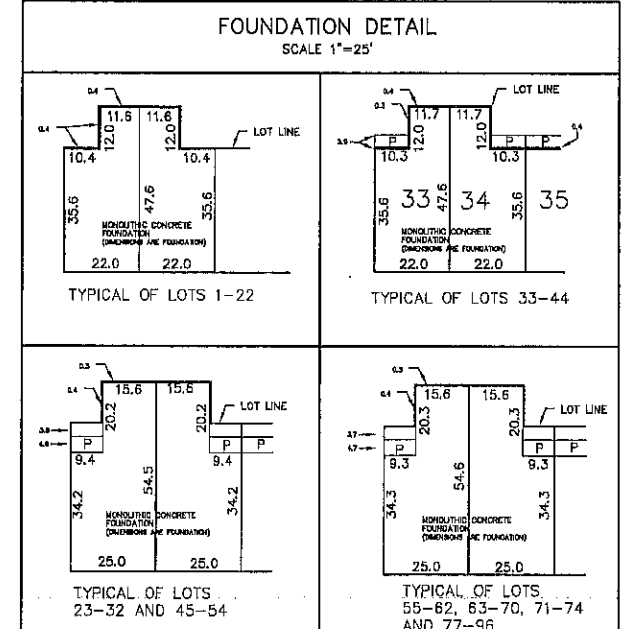
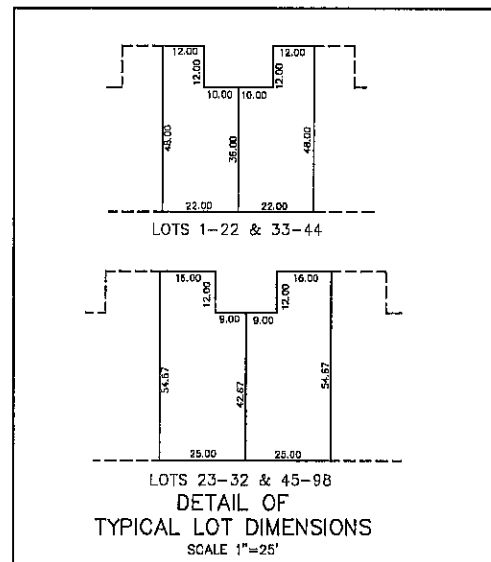
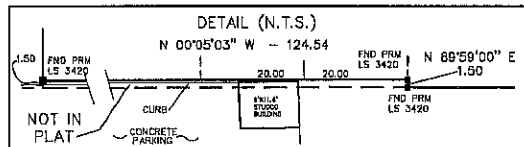

This is to certify that I have consulted National Flood Insurance Rate Map, effective December 8, 2022, for Okaloosa County, Florida, Map No. 120610488 H, and found the property described hereon to be located in Zone "X", area determined to be outside 500-year flood plain.

LOTS	FINISHED FLOOR ELEVATIONS (FFE)		GARAGE
	PLAN ELEVATIONS	EXISTING ELEVATIONS	
1-10	21.2	21.5	21.0
11-22	21.2	21.4	21.1
23-32	20.0	21.3	20.8
33-38	20.0	21.0	20.5
37-40	20.0	21.0	20.5
41-44	20.0	21.0	20.5
45-54	21.5	21.5	21.0
55-58	21.0	21.0	20.5
59-62	21.0	21.0	20.5
63-68	21.0	21.0	20.8
67-70	20.0	20.0	19.8
71-74	20.0	20.0	19.7
75-76	20.0	20.0	19.6
77-80	21.0	21.0	20.6
81-84	21.0	21.1	20.6
85-88	21.0	21.1	20.6
89-92	20.0	20.1	19.6
93-96	20.0	20.0	19.6
97-98	20.0	20.0	19.6

Ⓢ DENOTES BUILDING NUMBER

REVISIONS			
8-03-05	FOUNDATION ADDED BLDG 18	WO 05-1878	FB 05-12 PG 88-89
8-04-05	FOUNDATION ADDED BLDG 17	WO 05-1891	FB 05-12 PG 80-81
8-16-05	FOUNDATION ADDED BLDG 16	WO 05-2002	FB 05-14 PG 20,23-24
8-16-05	FOUNDATION ADDED BLDG 15	WO 05-2001	FB 05-14 PG 20,23-24
8-16-05	FOUNDATION ADDED BLDG 14	WO 05-2029	FB 05-14 PG 20,23-24
9-20-05	FOUNDATION ADDED BLDG 13	WO 05-2263	FB 05-15 PG 106-107
3-05-06	FOUNDATION ADDED BLDG 12	WO 05-0367	FB 05-4 PG 46-48
3-08-06	FOUNDATION ADDED BLDG 10	WO 05-0389	FB 05-4 PG 46-48
3-21-06	FOUNDATION ADDED BLDG 8	WO 05-0502	FB 05-5 PG 63-64
3-21-06	FOUNDATION ADDED BLDG 6	WO 05-0501	FB 05-5 PG 63-64
5-09-06	FOUNDATION ADDED BLDG 7	WO 06-0878	FB 06-6 PG 35-36
5-09-06	FOUNDATION ADDED BLDG 9	WO 06-0877	FB 06-6 PG 35-36
6-30-06	FOUNDATION ADDED BLDG 5	WO 06-1016	FB 06-7 PG 110-117
6-30-06	FOUNDATION ADDED BLDG 4	WO 06-1028	FB 06-7 PG 118
6-21-06	FOUNDATION ADDED BLDG 11	WO 06-1147	FB 06-8 PG 32-33
6-21-06	FOUNDATION ADDED BLDG 3	WO 06-1146	FB 06-9 PG 30-31
6-21-06	ADDED CROWN ELEVATIONS ON AIRPORT AND MATTIE M. KELLEY ROADWAYS		
6-29-06	POOL HOUSE ADDED	WO 06-1213	FB 06-7 PG 150-151
7-25-06	FOUNDATION ADDED BLDG 2	WO 06-1408	FB 06-10 PG 95
7-25-06	FOUNDATION ADDED BLDG 1	WO 06-1407	FB 06-10 PG 94

LEGEND

FB = FOUND BLDG
FIP = FOUND IRON PIPE
FWM = FOUND WOOD MEMBRANE
FND = FOUND NAIL AND DOG
FPC = FOUND POINT OF COMMENCEMENT
FOS = FOUND POINT OF BEGINNING
FOL = FOUND POINT OF LINE
FOP = FOUND POINT OF INTERSECTION
FPL = FOUND POINT OF LATERALITY
FPI = FOUND POINT OF INTERSECTION
FPP = FOUND POINT OF INTERSECTION
FPR = FOUND POINT OF INTERSECTION
FPT = FOUND POINT OF INTERSECTION
FPU = FOUND POINT OF INTERSECTION
FQ = FOUND POINT OF INTERSECTION
FR = FOUND POINT OF INTERSECTION
FS = FOUND POINT OF INTERSECTION
FT = FOUND POINT OF INTERSECTION
FU = FOUND POINT OF INTERSECTION
FV = FOUND POINT OF INTERSECTION
FW = FOUND POINT OF INTERSECTION
FX = FOUND POINT OF INTERSECTION
FY = FOUND POINT OF INTERSECTION
FZ = FOUND POINT OF INTERSECTION

DESCRIPTION LOTS 1-98, INCLUSIVE, QUAIL RUN TOWNHOMES

SECTION N/A TOWNSHIP 2-S RANGE 22W

RECORDED PLAT BOOK 22 PAGE 20

DEMONSTRATION NONE

UNDERGROUND ENCUMBRANCES (NOT LOCATED) NONE

SCALE 1" = 50' SURVEY DATE 7/28/06

ORDERED BY ROBERT DONOVAN CONSTRUCTION

PREPARED BY PANHANDLE ASSOCIATES INC.

DATE 7/28/06

RECORDED DATE 7/28/06

TYPE OF SURVEY BOUNDARY

PURPOSE FOUNDATION

PANHANDLE ASSOCIATES INC.
701-A EDGE STREET, FORT WALTON BEACH, FLORIDA 32247 (850) 654-1068 LAND SURVEYING BUSINESS LICENSE NO. 2355